

CENTRAL WASHINGTON UNIVERSITY
IET 265.001
ENGINEERING DESIGN USING SOLIDWORKS

INSTRUCTIONS FOR MODELING TYPICAL HEXHEAD UNIFIED FINE AND UNIFIED COURSE THREADED FASTENERS USING SOLIDWORKS 2010.

THIS EXERCISE UTILIZES THREADED FASTENER NOMENCLATURE TO DESIGN BOTH ENGLISH AND METRIC HEX HEAD BOLTS.

Requirements:

Precision to 3 significant digits (unless higher precision is needed)

Material: AISI 1045 Steel

Read and understand the information provided through the links on the Student Resources page of the Class Website

Table of formulas needed for this design:

Item Name	Letter	Formula	Derived	Location
Bolt Diameter	Db		Given	Bolt Nomenclature
Bolt Length	Lb		Given	Bolt Nomenclature
Threads per Inch	Ti		Given	Bolt Nomenclature (inches only)
Head Diameter	Dh		Look up	Website (consider 1.5 times Db)
Head Height	Hh	$Hh=Db*0.64$	Determine	
Head Chamfer Cut	Ch	$Ch=Hh*0.15$	Determine	
Hd Chamfer Angle		35 degrees		
Ring Shank Diam.	Ds	$Ds=Dh*0.90$	Determine	
Ring Shank Height	Hs	$Hs=Hh*0.05$	Determine	
Ring Shank Fillet	Rs	$Rs=Hs$	Determine	
Bottom Chamfer	Cb	$Cb= Dh *0.10$	Determine	
Bt. Chamfer Angle		45 degrees		
Thread Frequency	Tf	$Tf=1/Ti$	Determine	Inches only
Thread Frequency	Tf		Given	Bolt Nomenclature (metric only)
Thread Cut Pitch	Pt	$Pt=Tf$	Determine	

CENTRAL WASHINGTON UNIVERSITY
IET 265.001
ENGINEERING DESIGN USING SOLIDWORKS

Procedure:

1. Using the information and formulas on the hex bolt provided in the table nearby first, derive the unknown values then begin to build your model. Use between 3 and 4 significant digits. Think about the orientation of your model before you start so that the bolt is symmetrical about 2 planes. The surface on the bottom of the Ring Shank, below the head of the bolt, divides the top and bottom of the bolt. The plane that you sketch on initially can be used for insertion mating relations when this model is inserted into an assembly.

2. Sketch the diameter of the ring shank, using the dimensions derived for your design, and extrude it to the appropriate thickness. Name this base feature "Ring Shank" Wait until later for the fillets.

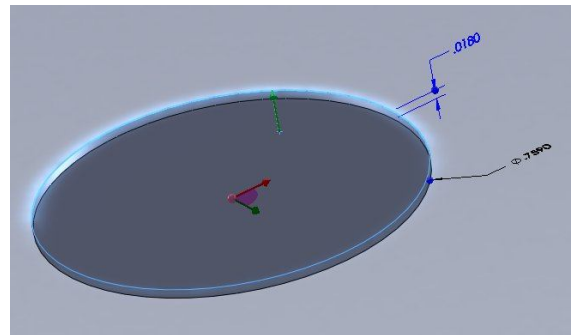

3. Sketch a hexagon, (Inscribed circle option) to represent the Bolt Head, on the surface of the Ring Shank with the appropriate derived dimensions. Fully define this sketch before extruding. One of the elements of definition is to apply a horizontal or vertical sketch relation to one of the sketch lines of the hexagon. Extrude this sketch the appropriate distance and name this feature. The following image is representative of a 9/16 bolt with 12 threads per inch which will be used throughout this example.

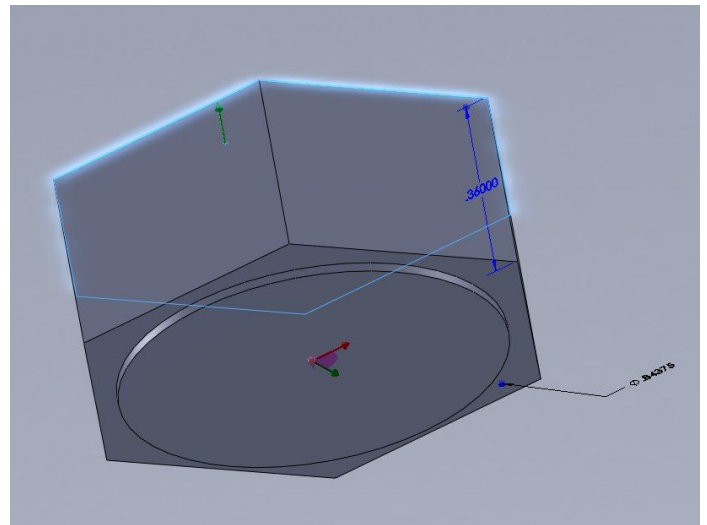

4. Create the Head Chamfer Cut guided by the information provided in the table above. Notice where the sketch plane is in reference to the side of the Bolt Head.

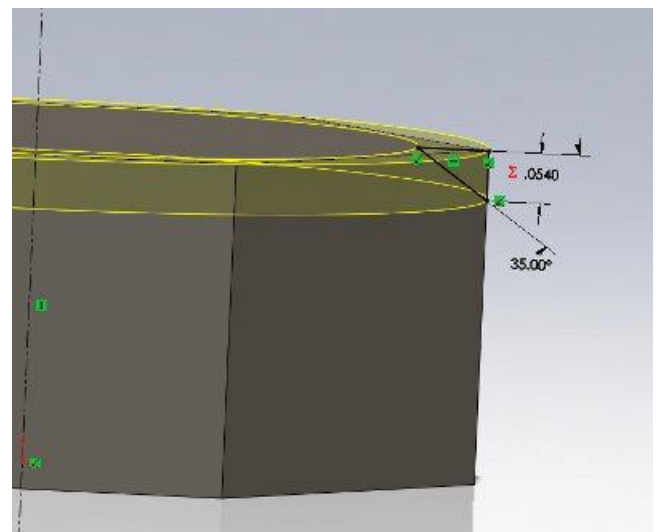

CENTRAL WASHINGTON UNIVERSITY
IET 265.001
ENGINEERING DESIGN USING SOLIDWORKS

5. Sketch the diameter of the Bolt Shank in the center of the bottom of the Ring Shank Feature and extrude to the length given to you for your design.
6. Apply the Ring Shank fillet feature between the Ring Shank and the bottom of the Bolt Head and between the Ring Shank and the Bolt Shank using the derived values given to you for your design.

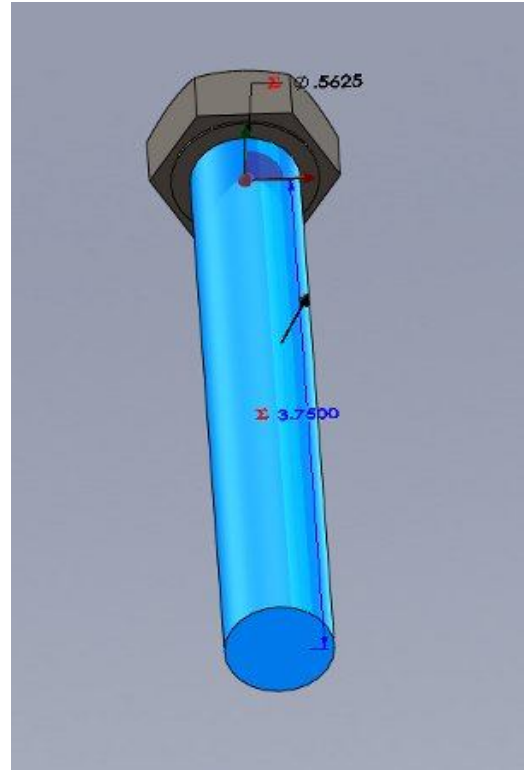
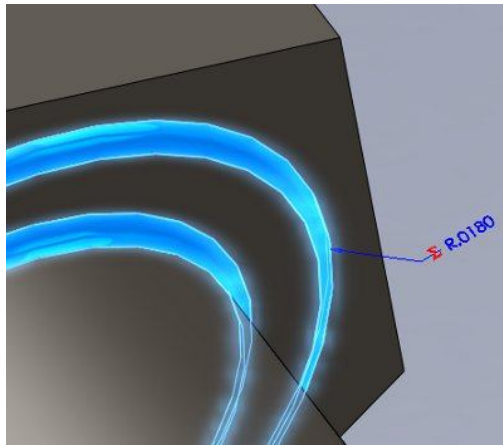

7. Apply the Bottom Chamfer feature using the derived values given to you for your design.

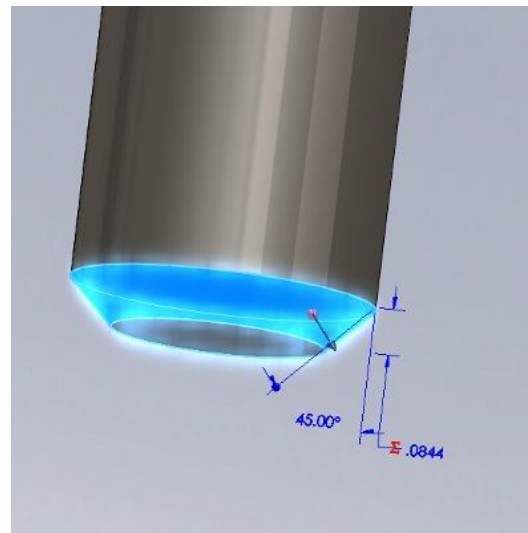

8. The final steps involve a Swept Cut feature involving a helix path and a specifically designed sketch for the cut profile. For the helix you need to sketch a circle as a parent for the Helix Feature. Select the bottom face of the Bolt Shank, start a sketch, select the outside circular edge of the shank and apply the Convert Entities sketch entity. This will project the circular edge of the Bolt Shank onto your sketch.

CENTRAL WASHINGTON UNIVERSITY
IET 265.001
ENGINEERING DESIGN USING SOLIDWORKS

9. Select the Helix and Spiral from the Features tab of the Command Manager.

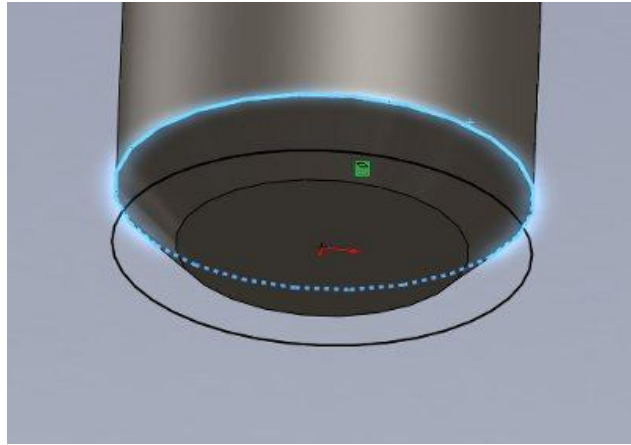
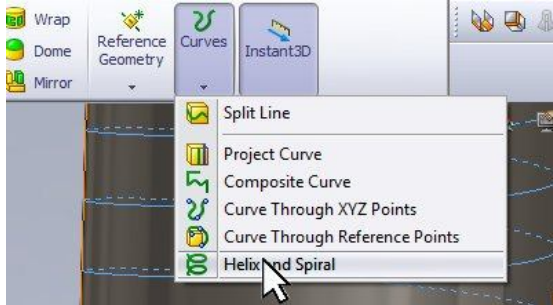

10. There are three selections to choose from when modeling a helix, we will choose the Height and Pitch selection since the thread length and Thread Cut Pitch will be given or derived. Enter the Height and Pitch of the helix in the places shown, check the Reverse Direction box, choose or enter the default start angle of 225 degrees and check the Clockwise radio button. Rename this sketch to Cut Path.

11. Now we need to sketch our cut profile. Select a primary plane that is perpendicular to the center axis of the bolt. I would suggest the following procedure for sketching. Sketch horizontal and vertical centerlines that have their midpoints intersect with each other. At this intersection, place a sketch point, in a similar manner, as you would do for a Hole Wizard feature.

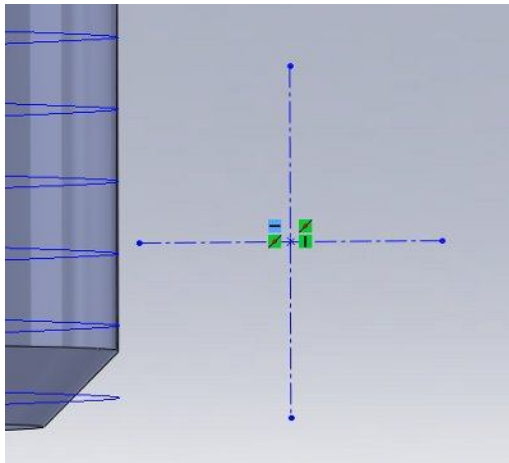
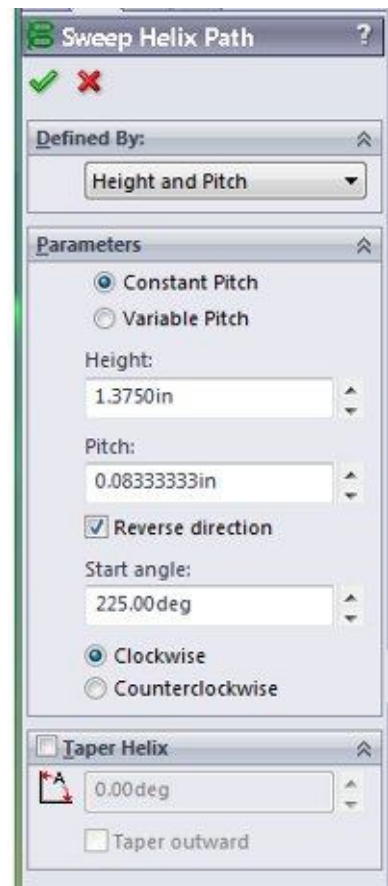

CENTRAL WASHINGTON UNIVERSITY
IET 265.001
ENGINEERING DESIGN USING SOLIDWORKS

12. Sketch a centerline at roughly a 30 degree angle and mirror it to the bottom using the horizontal center line as a mirror line. This establishes a symmetric relationship. Put a 60 degree angular dimension between these two lines.

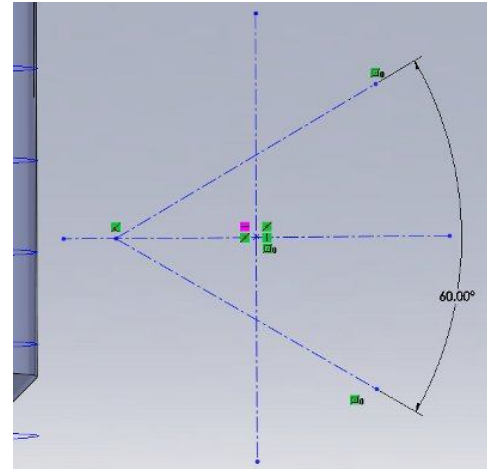

13. Roughly sketch a trapezoid on the centerlines draw as shown. Make certain the sketch lines are collinear with the center lines. The vertical lines should have a vertical Sketch Relation.

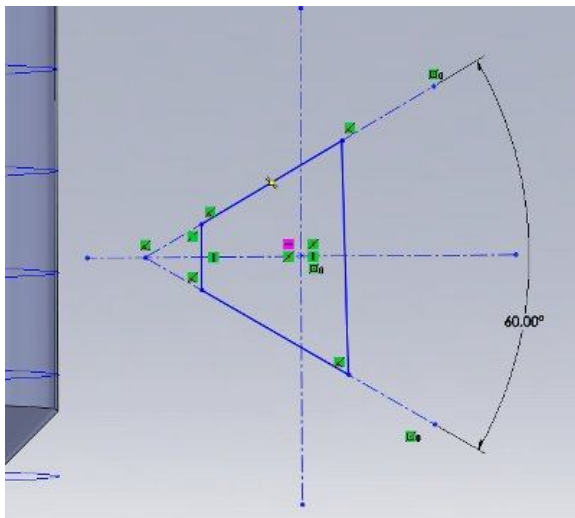

14. You will be placing three related dimensions on the following sides of your trapezoid. The longer vertical line will be the Pitch. This dimension represents one full cycle of cutting and is equal to the Pitch for the helix. The shorter vertical line is 0.25 times the Pitch. And the distance between the vertical centerline and the longer vertical line is 0.108 times the pitch (I did the trigonometry for you on this one).

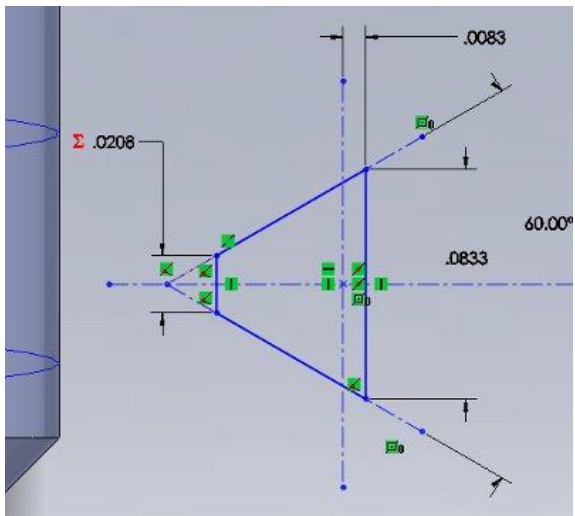

15. The sketch will not be fully defined until we apply a relation or dimension to some other geometry that is fully defined. In this example we will select the point at the intersection of the two centerlines and then also select the sketch line for the helix. Choose the "Pierce" Sketch Relation option for these selections. Rebuild or Exit Sketch. NOTE: You may have to alter the pitch (height) of the tool to get the sweep to work (zero point geometry), if so decrease the last digit (out of 3 or 4 significant digits) value by 1.

16. Rename this sketch to Cut Profile and apply the Swept Cut Feature using this sketch and the helix as a path.